

**DEEPSEA**  
Power & Light<sup>®</sup>



# Nano SeaLite<sup>®</sup>

High Resolution. Compact. Durable.



## Operator's Manual

# Specification Overview

NSL-T	
<b>Optical Specifications</b>	
Typical Lumen Output (Flood)	700
Efficacy	50 lm/w <sup>1</sup>
Color	Cool White 6500 K ~ 8000 K
CRI	Cool White: 70
Beam Angle (HPFW)	Flood: 70°
<b>Environmental Specifications</b>	
Depth Rating	6,000 m standard 11,000 m optional <sup>1</sup>
Operational Temperature	-10°C to 50°C [14°F to 122°F]
<b>Electrical Specifications</b>	
Voltage	10~36 VDC
Current	1.16A @ 12 V, 0.38A @ 36V
Power	14 W
<b>Mechanical Specifications</b>	
Housing	6Al-4V Titanium
Port	Sapphire
Outer Diameter	25 mm [0.99 in]
Overall Length (Without Connector)	6,000 m depth rating: 57.0 mm [2.25 in] 11,000 m depth rating: 68.6 mm [2.70 in]
Weight in Air	6,000 m depth rating: 140 g [4.9 oz] 11,000 m depth rating: 160 g [5.6 oz]
Weight in Water	6,000 m depth rating: 100 g [3.5 oz] 11,000 m depth rating: 47 g [1.7 oz]
<b>Connector</b>	
Default	SEACON MCBHMP SS Please contact sales for more options.

## 6,000 m Depth Rating

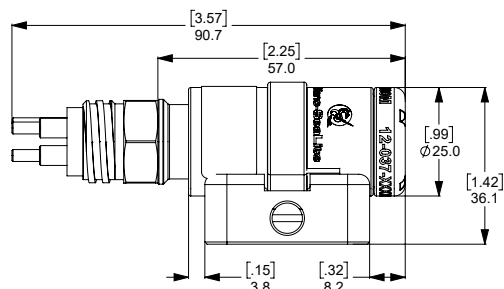

## 11,000 m Depth Rating

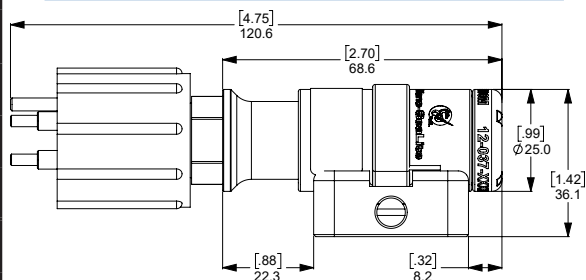

## Bracket

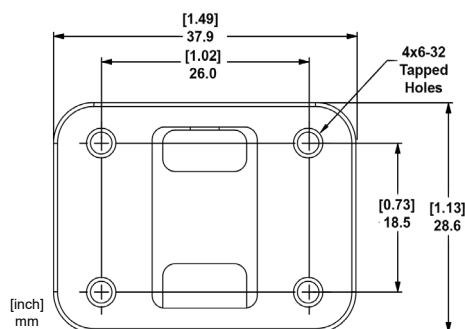

<sup>1</sup> Contact sales for 11,000 m depth rated connector options.

\* Specifications subject to change without notice.

# Table of Contents

Specification Overview .....	2
Table of Contents.....	3
Safety Symbols.....	4
General Notes and Warnings .....	4
Pre and Post Dive Inspection .....	4
Flooded Light Repair.....	4
Troubleshooting.....	5
Warranty Information.....	5

# Safety Symbol

In this operator's manual and on the product, safety symbols are used to communicate important safety information. This section is provided to improve understanding of these symbols.



This is the safety alert symbol. It is used to alert you to potential personal injury hazards. Obey all safety messages that follow this symbol to avoid possible injury or death.



**DANGER** indicates a hazardous situation which, if not avoided, could result in death or serious injury.



**WARNING** indicates a hazardous situation which, if not avoided, could result in damage to the product or bodily harm.



**CAUTION** indicates a hazardous situation which, if not avoided, could result in minor or moderate injury.



**NOTICE** indicates information that relates to the protection of property.



This symbol means read the operator's manual carefully before using the equipment. The operator's manual contains important information on the safe and proper operation of the equipment.



This symbol means always wear safety glasses with side shields or goggles when handling or using this equipment to reduce the risk of eye injury.



This symbol indicates the risk of electrical shock.

## General Notes and Warnings

The Nano SeaLite can be run in air, but will go into thermal rollback, where its light output diminishes to protect the light from overheating. This is normal and purposely designed to protect the LEDs from being damaged by excess heat buildup while running in air. The light will return to full brightness once it is submerged in water or allowed to cool down. Thermal rollback will not happen when light is operated in water under normal usage.



When the Nano SeaLite is operated in air, the body may reach temperatures in excess of 65° C. These temperatures may be enough to cause burns if the light is handled without protective clothing.



Do not operate any high voltage electrical equipment in or around water without using a Ground Fault Circuit Interrupter (GFCI) and an isolation transformer, especially when divers are in the water.

## Pre and Post Dive Inspection

Rinse your Nano SeaLite in fresh water after use in saltwater.

Always check to make sure that the rear bulkhead connector assembly is secure before deployment. Before and after each deployment, check the following areas for damage, wear or corrosion:

- Rear bulkhead connector assembly
- Power cable
- Front window



After each deployment, carefully check to make sure the light has not flooded. It is possible for the light to partially flood and then reseal itself while underwater. Upon surfacing, the light can become internally pressurized, which may be potentially dangerous. Additionally, if the power remains on when the light has partially flooded, it is possible for electrolytic generation of an explosive mixture of hydrogen and oxygen gases. If a light appears flooded upon removal from the water, it should be treated as potentially dangerous. Point the light away from persons and valuable equipment and make sure that the power is disconnected.

## Flooded Light Repair



If the light stops working while underwater, you should assume that it has been flooded. When working on

a potentially flooded light, it is important to use appropriate personal protective equipment to include, at a minimum, eye and hand protection.

1. Immediately turn off the power to the unit.
2. Place the light face down on a table making sure that the connector side is facing up.
3. Using a small flat screwdriver, remove the retaining ring that holds the endcap assembly in its place.
4. With the retaining ring off, grab the connector and slowly pull it straight up and out of the housing allowing any internal pressure to be equalized.
5. Pour out any water trapped in the housing.
6. Once it is determined that the light is not internally pressurized, it is recommended that the light be returned to DeepSea Power & Light (DSPL) for evaluation and repair using the RMA Procedure.
7. In case of emergency, you may attempt to repair the flooded light. Any parts that were exposed to saltwater should be cleaned with de-ionized water to remove any salt residue before reassembly. Make sure that all parts are completely dry before reassembly by baking them in an oven at 140°F for 30 minutes.

## NOTICE

IMPORTANT! DeepSea Power & Light cannot be responsible for any damage incurred during emergency field repairs. Such repairs should be undertaken only as a last resort and by qualified personnel.

## Troubleshooting

1. If the light stops working while underwater assume that it has been flooded. See Flooded Light Repair procedure.
2. Once it has been determined that the light is not flooded, or if it does not turn on during pre-deployment checks, troubleshoot in the following sequence:
  - a. Check the power cable/inline connector to make sure that correct voltage and current are being supplied, and that the correct pin-outs are being used. See the 2nd page this manual for electrical specs and connector pin-outs.
  - b. Remove the connector (see step 2 in the Flooded Light Repair procedure). Inspect the assembly for visual signs of wear. Using a multi-meter check for continuity or shorts in the connector. Try a spare connector if available.
  - c. Check the wires that go from the driver board to the connector for wear. If they appear worn, replace them.
  - d. Check to make sure that the driver board is securely attached to the lighthouse. If it is loose, check for damage on the board. If there appears to be no damage, reattach the driver to the lighthouse. Try using a spare driver board if available.
  - e. If the light still does not work, return it to DSPL using the RMA Procedure.

## RMA Procedure for Repair

Should it be necessary to return your light to the factory, follow the procedure for the Flooded Light Repair above, and by leaving the connector partially unscrewed.

For warranty and non-warranty repairs, please contact DeepSea Power & Light for an RMA number prior to returning your item. Please have your light model number, serial number and any other pertinent information along with a description of the problem on hand when you call, or include them in a fax or email. When shipping your item, be sure that the freight is pre-paid (CODs will not be accepted) and that the RMA number is clearly printed on the outside of the box. All shipments should be sent to the address below:

**DeepSea Power & Light**  
**Attn: RMA ####**  
**4033 Ruffin Road**  
**San Diego, CA 92123-1817**  
**U.S.A**  
**Tel: (858) 576-1261**  
**Fax: 858-576-0219**  
**Email: RMA@deepsea.com**

## Warranty Information

### Limited Warranty

Seller warrants that the goods (except internal electronic components) sold under this contract will be free from defect in material and workmanship for a period of one year from the date of shipment from the factory, if they have been properly used. Internal electronic components are warranted for 90 days from the date of shipment from the factory, if they have been properly used. This warranty will be limited to the repair or replacement of parts and the necessary labor and services required to repair the goods. IT IS EXPRESSLY AGREED THAT THIS WARRANTY WILL BE IN LIEU OF ALL WARRANTIES OF FITNESS AND IN LIEU OF THE WARRANTY OF MERCHANTABILITY. This warranty is the exclusive and only warranty to pass with the goods under this contract. No agent, employee, or representative of the Seller has any authority to bind Seller to any information, representation, or warranty concerning the goods

sold under this contract, and unless an affirmation, representation, or warranty made by an agent, employee, or representative is specifically included within this contract, it will not be enforceable by Buyer. If notice of defect is given to DeepSea Power & Light LLC within such 90 day or one year warranty period, the sole obligation of DeepSea Power & Light LLC shall be to furnish new or repaired parts free of charge in exchange for parts which have been proved defective and does not include any other costs such as the cost of removal of the defective part, installation, labor or consequential damages of any kind, the exclusive remedy being to require DeepSea Power & Light LLC to furnish such new parts. Under no circumstances shall the Buyer be entitled to recover any incidental damages as that term is defined in Commercial Code §2715.



T: (858) 576-1261    [www.deepsea.com](http://www.deepsea.com)  
F: (858) 576-0219    [sales@deepsea.com](mailto:sales@deepsea.com)

